

Pressure Precision

with internal diaphragm
for gauge pressure and absolute pressure

accuracy 0.05% and 0.1 %

standard output: RS 232-interface
or 4...20 mA; 2-wire system
or 0...20 mA; 3-wire system



Description

Pressure sensors Precision are top of the range precision pressure sensors.

With a standard accuracy of 0.1% and optional accuracy of 0.05%, these pressure sensors are particularly suitable for use in testing or calibration systems. The program-controlled temperature compensation system practically eliminates temperature-related measurement errors in the range 0°C to 50°C.

The front flush pressure diaphragm avoids zones, in which medium could crystallize or residues could form, thus ensuring trouble-free pressure measurement and hygienic cleaning of the pressure sensor.

Their long-term stability, good corrosion resistance, high protection (IP 67) and mechanical load rating also make the pressure sensors precision suitable for use in demanding measuring jobs in harsh industrial environments.

For special measuring jobs, the zero point and measuring range can be reset with an IBM compatible PC. The necessary software for this and for the determination, storage and output of the measured values can be supplied.

The pressure sensors Precision meet the electromagnetic compatibility (EMC) to EN 61326.

Features

- High accuracy
- High long-term stability
- Temperature influence practically none
- Corrosion resistant stainless steel design
- Serial interface

Measuring ranges

Gauge pressure

negative -1...0 bar to -0.25...0 bar

positive 0...0.25 bar to 0...1000 bar

Absolute pressure 0...0.25 bar to 0...16 bar

Applications

Testing and calibration systems,
Development and production.

Models: P3382

Technical data

Model	P3382			Option
Pressure type	negative or positive gauge pressure		absolute pressure	negative and positive gauge pressure
Output signal	4 ... 20 mA - 2-wire system 0 ... 20 mA - 3-wire system RS 232-interface			0...5 VDC; 0...10 VDC; 4 ... 20 mA 3-wire system
Accuracy % of F.S. 1)	± 0.1 % of F.S.			± 0.05 % of F.S.
Ranges accord. to EN	0 ... 0.25 bar to 0 ... 16 bar	0 ... 25 bar to 0 ... 1000 bar	0 ... 0.25 bar to 0 ... 16 bar	0 ... 1600 bar
Sensor element	Piezoresistive	thin film	piezoresistive	
Repeatability	≤ ± 0.03 % of F.S.			
Stability (annual)	≤ ± 0.1 % of F.S. in rated conditions			
Case	Stainless steel 1.4571			
Pressure connection	G ½ B accord. to DIN 16 288			G¼B; ½NPT; ¼NPT
Wetted parts	Stainless steel 1.4571			
Overload limit	≤ 16 bar 3.5-fold; ≤ 600 bar 2-fold; > 600 bar 1.5-fold;			
Electrical connection – analogue output – RS 232-interface	cable outlet with 1.5m cable 9-pin sub-D plug			8-pin plug
Power supply – analogue output – RS 232-interface	14...30 VDC, (10...30 VDC for output 4...20 mA 2 wire) supply from interface			
Power consumption	max 30 mA current output < 25 mA voltage output			
Load – current output (3-L) – current output (2-L) – 0...5 V – 0...10 V	$RA[\Omega] \leq (UB[V] - 14V) / 0.02 A$ $RA[\Omega] \leq (UB[V] - 10V) / 0.02 A$ > 5 kOhm > 10 kOhm			
Temp. compens. range	-20... 80°C			
Temperature influence – -20...0°C – 0...50°C – 50...80°C	≤ 0.1 % /10 K, on zero and span None ≤ 0.1 % /10 K, on zero and span			
Adjustability – analogue output – RS 232-interface	of zero and span; programmable Software and cable set available as accessoires Software incl. in delivery contents			
Response time	≤ 80 ms (within 10 % to 90 % of F.S.)			
Protection type	IP 67 EN 60 529 / IEC 529			IP 65 with plug
Emission 2)	to EN 61326			
Interference 2)	to EN 61326			
Temperature ranges – Storage – Medium – Ambient	-40 85 °C -20 80 °C -20 80 °C			
Weight	Approx. 0.30 kg			

of F.S. = of full scale value

- 1) Terminal point adjustment according to DIN 16 086, incl. linearity and hysteresis (calibrated in vertical installation position, pressure connection bottom)
- 2) Declaration of conformity on request

Dimensions (mm)

Case

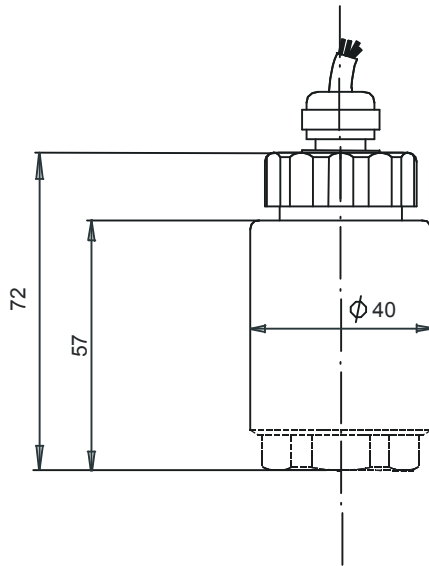

Pressure connection

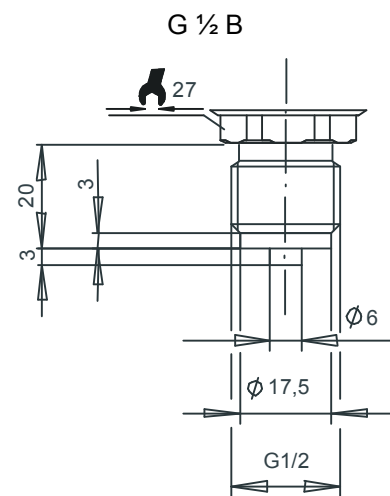
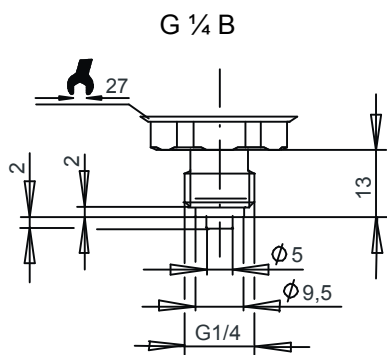

Screw-in aperture to DIN 16 288

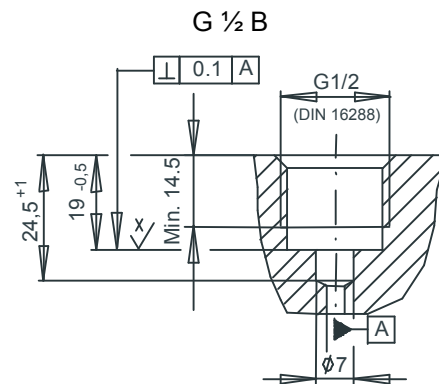
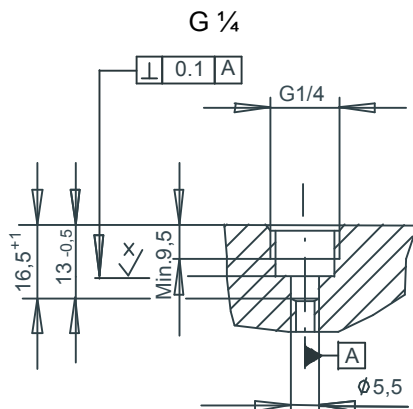

Electrical connection

Two-wire-system

Cable outlet

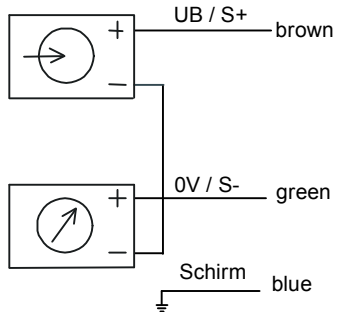

8-pin connector

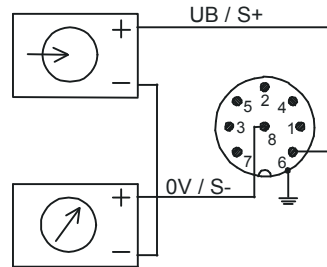

Three-wire-system

Cable outlet

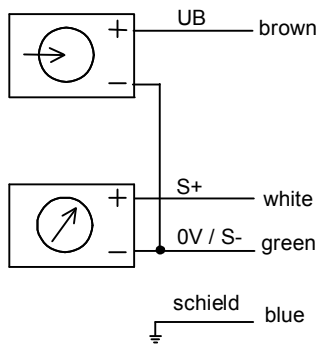

8-pin connector

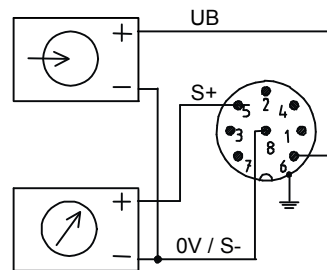

RS 232 Interface

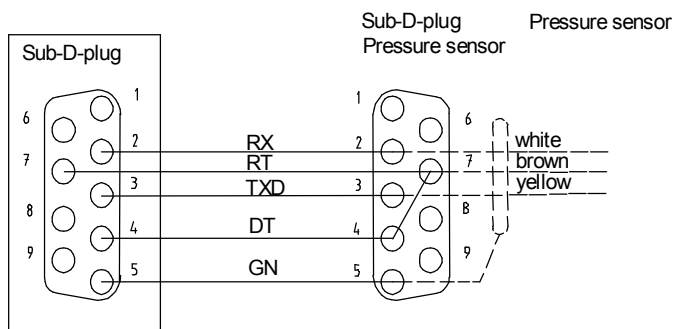

Order details

1. Model
2. Measuring range
3. Output signal
4. Options