

## Standard system contact pressure gauges for the chemical industry with or without dampening

for special safety  
with magnetic snap-action contacts  
or inductive alarm contacts

Nominal sizes ND 100

Connection position bottom, radial



### Description

Contact pressure gauges with electrical alarm contacts are suitable for controlling or regulating process sequences. The contacts open or close electrical circuits in relation to the position of the pointer on the pressure gauge.

Contact pressure gauges with the Bourdon tube system are used at process pressures of approximately 1 bar and upwards. The materials used make the gauges suitable for chemically aggressive gases or liquids, although these may not be too viscous or be susceptible to crystallization. A laminated safety pane, unbreakable partition between the measuring system and dial and a blow-off back cover help to prevent accidents caused by escaping media or projected parts and thus injuries to employees if a pressure overload of the gauge occurs.

The inexpensive tried and tested Bourdon tube system coupled with a modern modular principle provides a very reliable yet inexpensive contact pressure gauge.

Gauges with liquid filling are damped if pressure pulses or mechanical vibrations arise. This extends the service life and the gauge display remains largely vibration free.

Electrical alarm contacts are used as magnetic snap-action contacts, especially in harsh industrial conditions. The high contact pressure and the choice of different electrical contact materials enable high currents to be switched reliably. **If the electrical switching capacities of the alarm contacts are exceeded or not reached (see DE 1231), a relay is to be used to provide an appropriate current rating (DE 1230).**

Inductive alarm contacts operate without physical contact and thus have no unfavourable effects on the pressure measuring system while having an unlimited service life. A control unit is always needed to operate these contacts. Contact pressure gauges with inductive alarm contacts can be used in potentially explosive atmospheres, provided that the appropriate regulations are complied with.

### Features

- o Modular construction system ensures high reliability and long service life
- o Special safety
- o Liquid dampening through vibration-free display
- o Chemical resistant due to stainless steel design
- o Overload capacity 1.3 x
- o Protection to IP 65
- o Accuracy class 1.0
- o Case, stainless steel 1.4301
- o Measuring system stainless steel 1.4571
- o Up to four alarm contacts possible
- o Suitable for programmable controller

### Ranges

0 ... 1 bar to 0 ... 1000 bar

### Applications

Process engineering,  
mechanical engineering and plant construction,  
water treatment.

Models: 2141, 2143, 2153

## Technical data

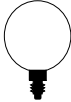
Models	2141	2143	2153	Options	
Nominal size	100				
Symbol					
Contact type	Magnetic snap-action	Inductive alarm	Inductive snap-action		
Number of contacts *	1 to 4 depending on measuring range	1 to 3 depending on measuring range	1 to 3 depending on measuring range		
Liquid filling	--	--	Polybutene		
Electrical connection	Cable connector right hand side. 6 screw terminals + PE, cross section of the conducting wire 2.5 mm <sup>2</sup> Screw type conduit fitting M20x1.5, outgoing downwards				
Accuracy class	1.0 to EN 837-1				
Ranges	0 ... 1 bar to 0 ... 1000 bar negative or positive / negative and positive gauge pressure				
Application	Constant load: up to full scale value Alternating load: up to 0.9 x full scale value short-time: Overload capacity 1.3 x				
Bottom cover	Stainless steel 1.4301				
Case	Stainless steel 1.4301				
Bezel	Stainless steel 1.4301				
Mounting flange	none				Stainless steel 1.4301, front flange
Window	Laminated safety glass				
Dial	Aluminium, white, scale and imprint black				
Pointer	Aluminium, black				
Movement	Stainless steel				
Measuring element	Stainless steel 1.4571				
Pressure connection - Position - thread	Stainless steel 1.4571 radial, bottom G 1/2 B ISO 228			1/2-14 NPT Other threads on request	
Temperatures - Medium - Ambient	Tmin. -20°C, Tmax. 80° C Tmin. -25°C, Tmax. 60° C			Tmax. 100° C	
Temperature drift	0.4%/10K if deviation from normal temperature 20°C				
Protection to EN 60 529/IEC 529	IP 54	IP 54	IP 65		
Orifice				ø 0.5 ; ø 0.8	
Weight approx.	0.9 kg	0.9 kg	1.2 kg		

### \* Number of contacts

Measuring range	Magnetic snap-action contact	Inductive contact
to 1 bar	1	1
1.6 bar	2	3
above 4 bar	4	3

See data sheet - DE 1231 for electrical data

See data sheet - DE 1230 for electrical data

## Dimensions

Connection position bottom, radial      Models: 2141, 2143, 2153  
Version to EN 837-1 for special safety

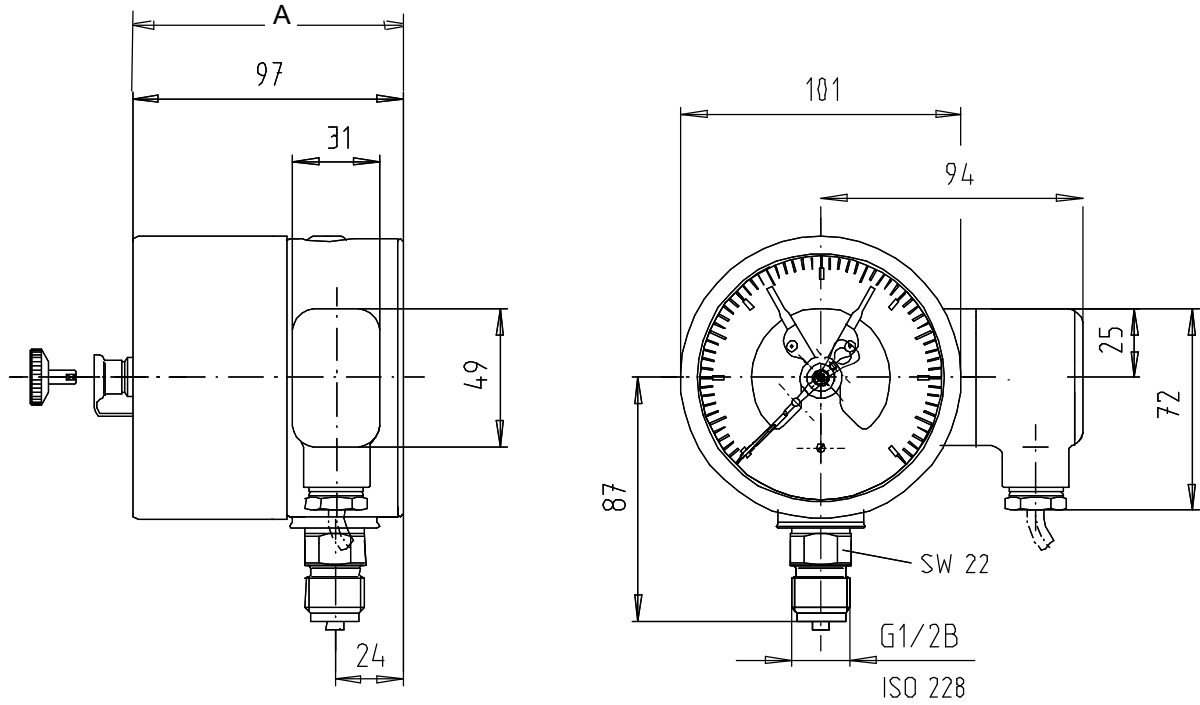

Models	2141, 2143	2153
Dimension "A"	104 mm	108 mm

Modifications reserved