

Modello AV2

- Motore A.C. monofase-trifase CE
- Riduttore vite senza fine - ruota elicoidale
- Stelo filettato trapezoidale e ricircolo di sfere
- Asta traslante in acciaio cromato
- Lubrificazione a grasso
- IP 50 / IP 65
- Temperatura di funzionamento -10°C +60°C
- Impiego intermittente S3 30% (5 min) a 30°C*
- Fine corsa, potenziometro ed encoder a richiesta

(*) Per impieghi diversi contattare il Ns Ufficio Tecnico

Model AV2

- Three phase or single phase motor CE
- Worm gearbox
- ACME lead screw and ballscrew
- Chrome plated steel push rod
- Lubrication by grease
- IP 50 / IP 65
- Temperature range -10°C +60°C
- Intermittent duty S3 30% (5 min) @ 30°C*
- Limit switches, potentiometer and encoder on demand

(*) For any special duty please contact our offices

AV2 (Vac)

Fmax	Velocità	Versione	Taglia motore	Potenza motore	Giri motore	Rapporti Riduzione	D vite	Passo	Rendimento	Corsa max [mm]	
Fmax	Speed	Version	Motor size	Motor power	Motor speed	Gearbox Reduction Ratio	Screw D	Pitch	Efficiency	Max stroke (mm)	
[N]	[mm/s]			[kW]	[rpm]		[mm]	[mm]		con FC / with FC	senza FC / without FC
2000	30,0	M01	IEC71	0,25	1400	3/17	18	8	0,27	935	935
5000	15,0	M02	IEC71	0,37	1400	3/17	18	4	0,24	590	590
7500	10,0	M03	IEC71	0,37	1400	2/20	18	4	0,21	485	485
10000	5,0	M04	IEC71	0,25	1400	1/20	18	4	0,20	420	420

AV2-VRS (ballscrew) (Vac)

Fmax	Velocità	Versione	Taglia motore	Potenza motore	Giri motore	Rapporti Riduzione	D vite	Passo	Rendimento	Corsa max [mm]	
Fmax	Speed	Version	Motor size	Motor power	Motor speed	Gearbox Reduction Ratio	Screw D	Pitch	Efficiency	Max stroke (mm)	
[N]	[mm/s]			[kW]	[rpm]		[mm]	[mm]		con FC / with FC	senza FC / without FC
1000	40,0	M01	IEC56	0,09	2800	3/17	16	5	0,65	845	845
2000	20,0	M02	IEC56	0,11	1400	3/17	16	5	0,65	785	785
5000	10,0	M03	IEC56	0,11	1400	2/20	16	5	0,56	495	495
7500	5,0	M04	IEC56	0,11	1400	1/20	16	5	0,54	405	405

Nota: con motore Vac monofase il valore "Fmax [N]" diminuisce del 35%.

Note: "Fmax [N]" is 35 % lower when a single phase motor is used.

AV2 - Versione C.A. / A.C. Version

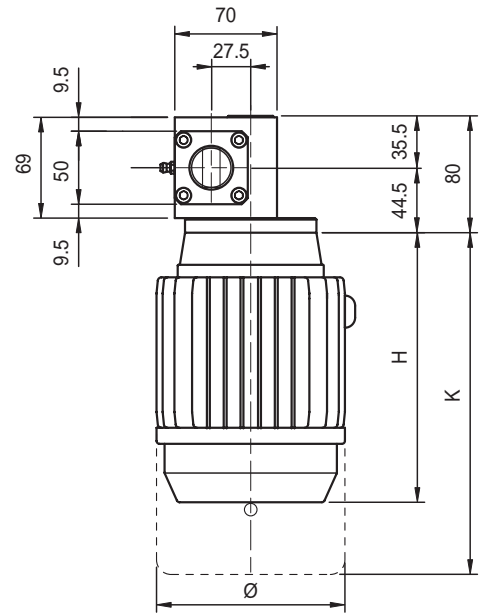
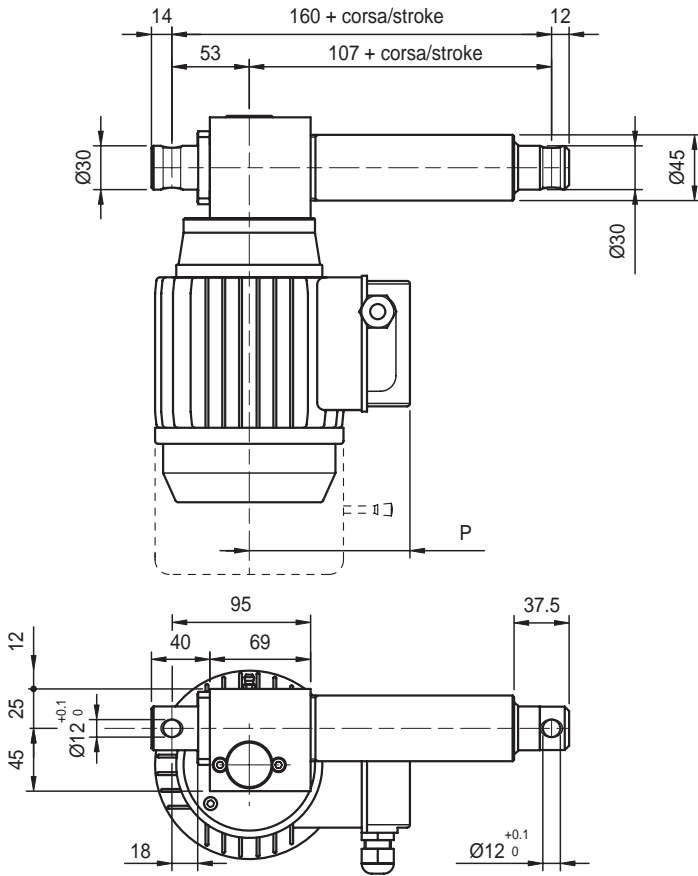

DIMENSIONI MOTORI C.A. / A.C. MOTORS DIMENSIONS					
GR. / SIZE	VERSIONE / TYPE	H	K	Ø	P
56	Standard	179		116	108
	Autofrenante / Brake motors		211		
63	Standard	196		129	110
	Autofrenante / Brake motors		245		
71	Standard	226		146	121
	Autofrenante / Brake motors		278		

AV2-F - Versione C.A. / A.C. Version

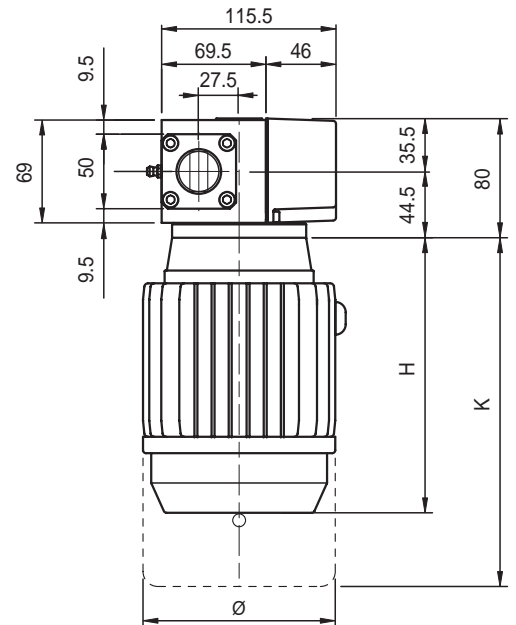
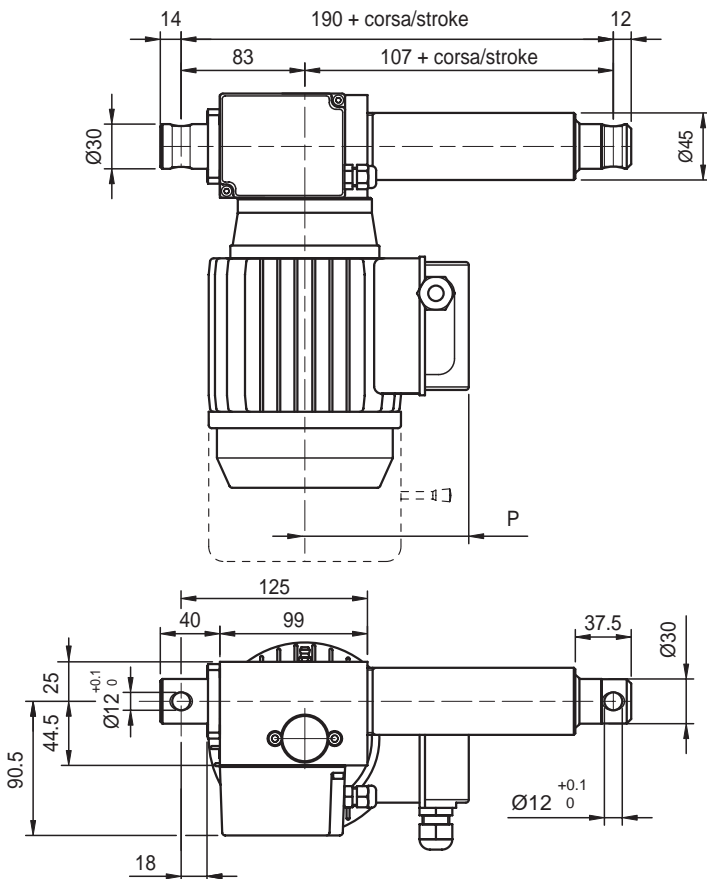

DIMENSIONI MOTORI C.A. / A.C. MOTORS DIMENSIONS					
GR. / SIZE	VERSIONE / TYPE	H	K	Ø	P
56	Standard	179		116	108
	Autofrenante / Brake motors		211		
63	Standard	196		129	110
	Autofrenante / Brake motors		245		
71	Standard	226		146	121
	Autofrenante / Brake motors		278		

AV2-FCM - Versione C.A. / A.C. Version

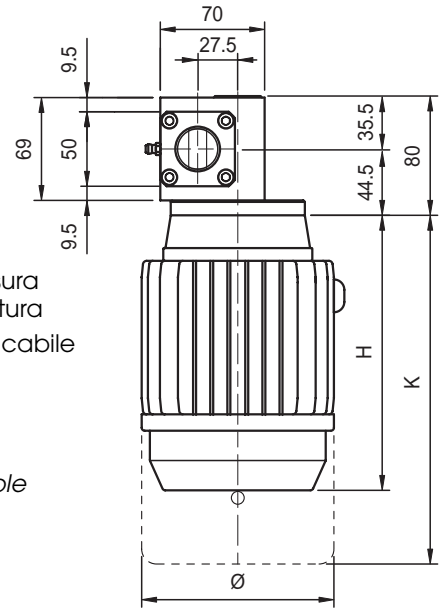
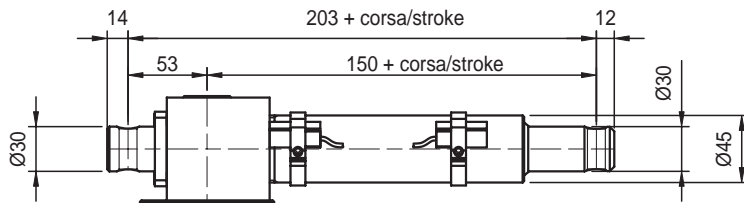

FCMC = Finecorsa magnetico chiusura
FCMA = Finecorsa magnetico apertura
N.B.: In questa versione non è applicabile l'opzione dell'antirrotazione.

FCMC = Closing magnetic switch
FCMA = Opening magnetic switch

Note: Antirotation key is not available in this version

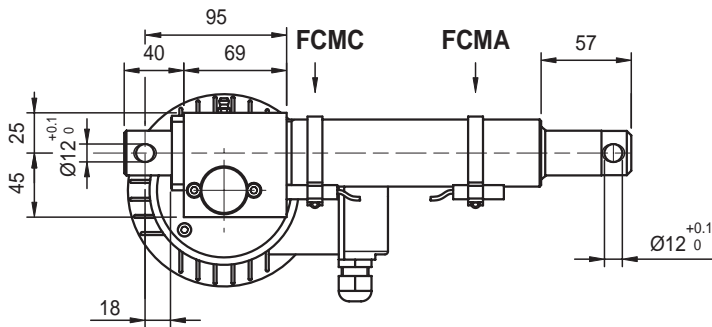

DIMENSIONI MOTORI C.A. / A.C. MOTORS DIMENSIONS					
GR. / SIZE	VERSIONE / TYPE	H	K	Ø	P
56	Standard	179		116	108
	Autofrenante / Brake motors		211		
63	Standard	196		129	110
	Autofrenante / Brake motors		245		
71	Standard	226		146	121
	Autofrenante / Brake motors		278		

AV2-VRS - Versione C.A. / A.C. Version (ballscrew)

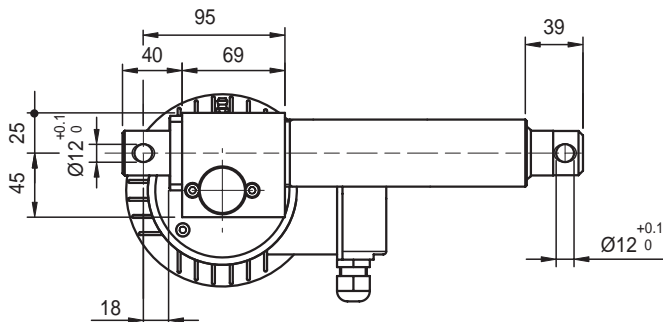
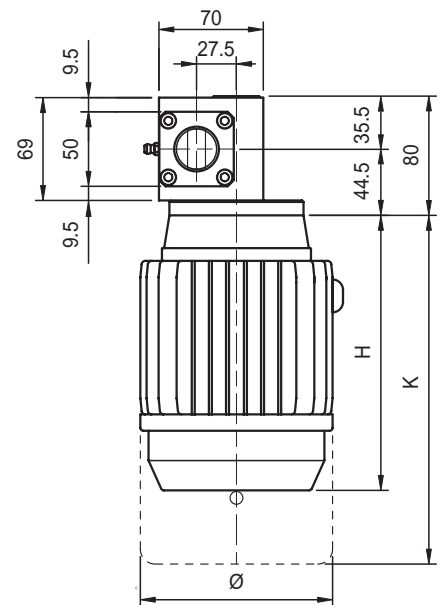
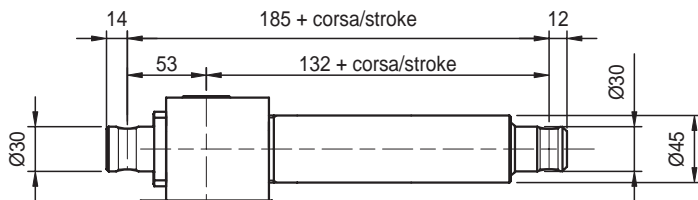

DIMENSIONI MOTORI C.A. / A.C. MOTORS DIMENSIONS					
GR. / SIZE	VERSIONE / TYPE	H	K	Ø	P
56	Standard	168		116	108
	Autofrenante / Brake motors		200		
63	Standard	185		129	110
	Autofrenante / Brake motors		234		
71	Standard	220		146	121
	Autofrenante / Brake motors		267		

AV2-VRS-F - Versione C.A. / A.C. Version (ballscrew)

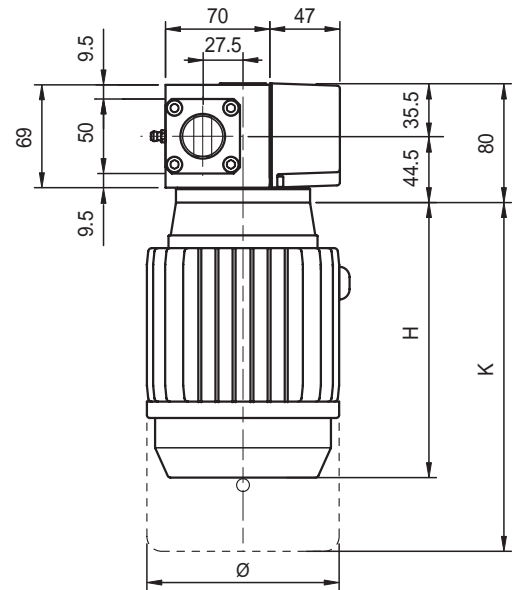
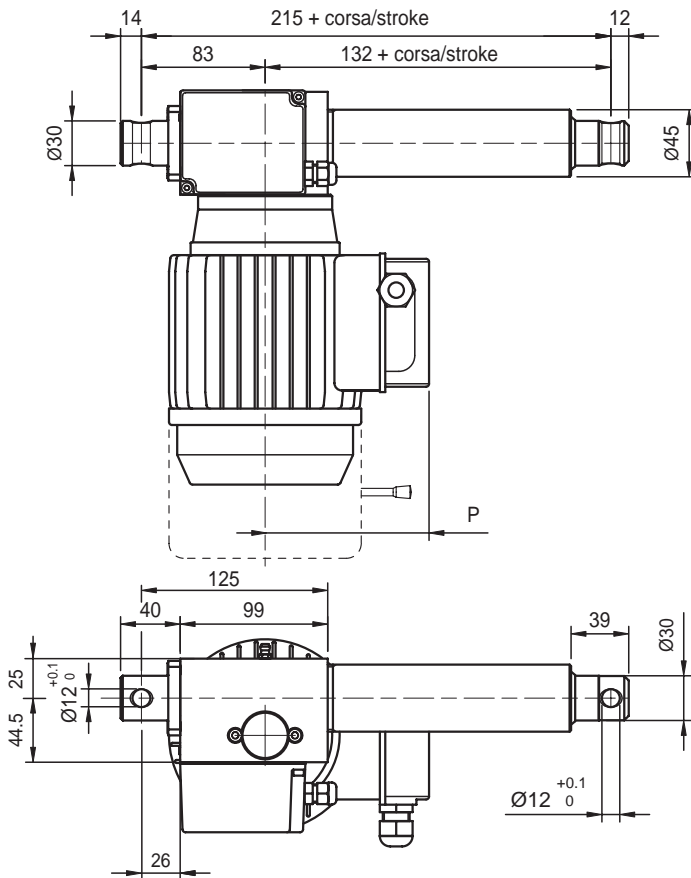

DIMENSIONI MOTORI C.A. / A.C. MOTORS DIMENSIONS					
GR. / SIZE	VERSIONE / TYPE	H	K	Ø	P
56	Standard	168		116	108
	Autofrenante / Brake motors		200		
63	Standard	185		129	110
	Autofrenante / Brake motors		234		
71	Standard	220		146	121
	Autofrenante / Brake motors		267		

AV2-VRS-FCM - Versione C.A. / A.C. Version (ballscrew)

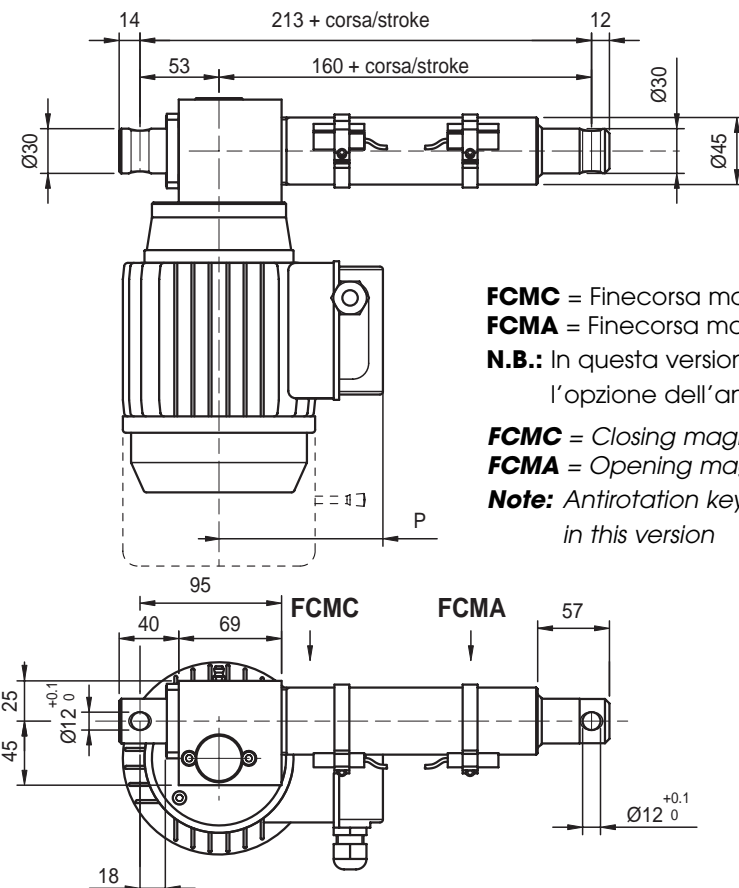

FCMC = Finecorsa magnetico chiusura
FCMA = Finecorsa magnetico apertura
N.B.: In questa versione non è applicabile l'opzione dell'antirotazione.
FCMC = Closing magnetic switch
FCMA = Opening magnetic switch
Note: Antirotation key is not available in this version

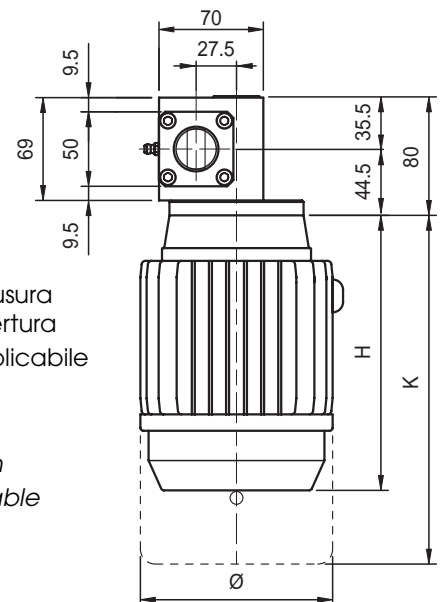

DIMENSIONI MOTORI C.A. / A.C. MOTORS DIMENSIONS					
GR. / SIZE	VERSIONE / TYPE	H	K	Ø	P
56	Standard	179		116	108
	Autofrenante / Brake motors		211		
63	Standard	196		129	110
	Autofrenante / Brake motors		245		
71	Standard	226		146	121
	Autofrenante / Brake motors		278		

Attacchi anteriori

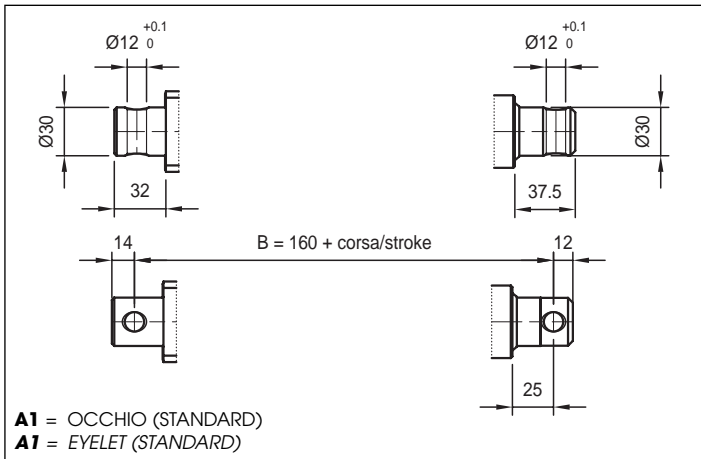

Front ends

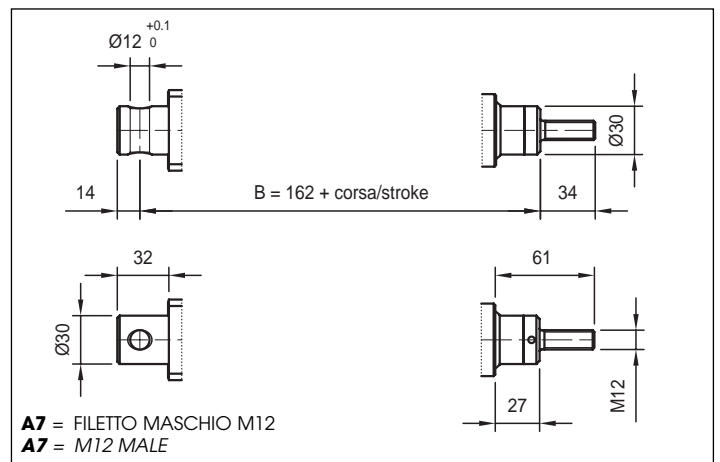
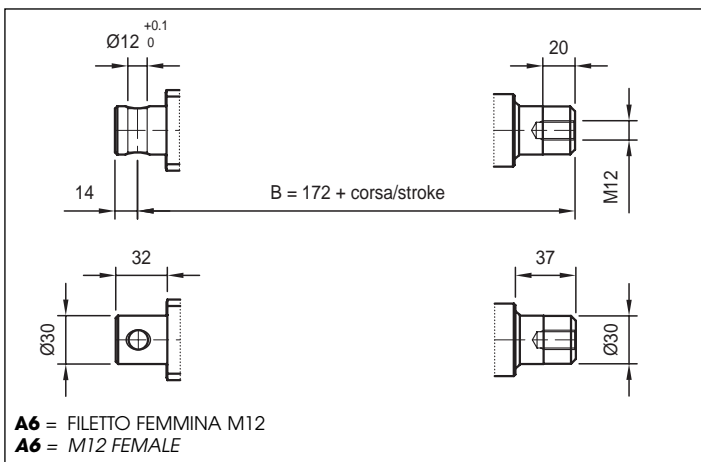
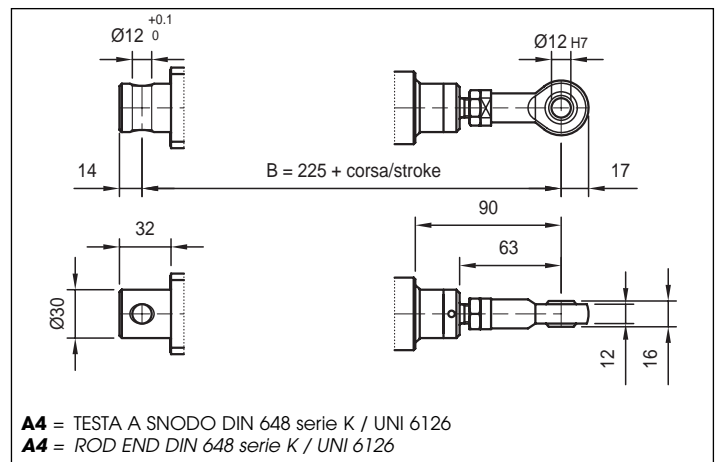
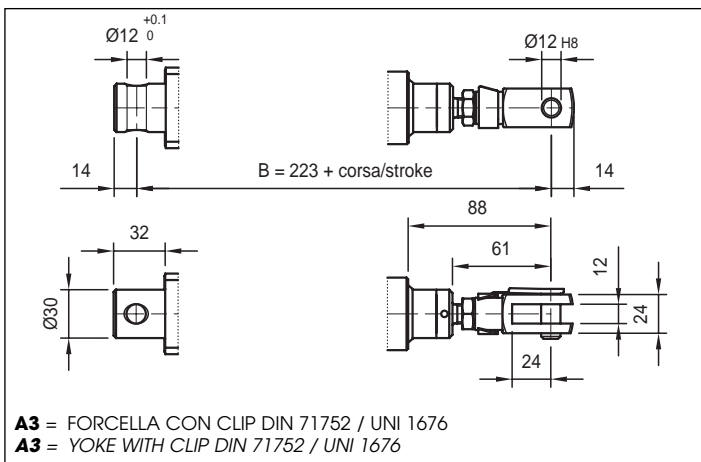
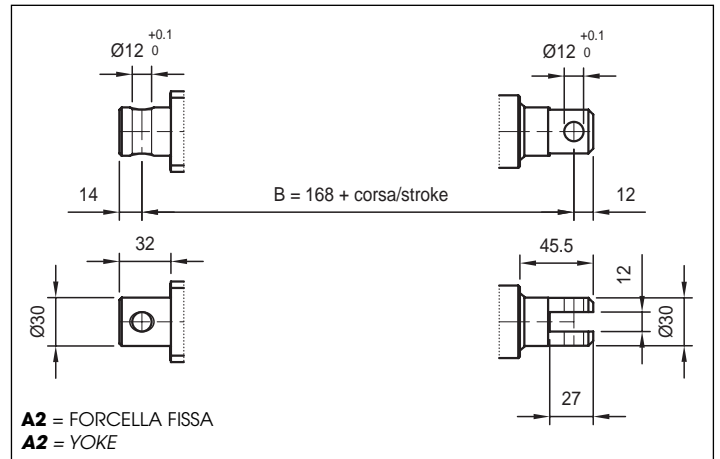

N.B.: Variazioni quota "B" in base al modello

Note: "B" dimension variations depending on model

AV2 = Vedi figure / See pictures

AV2-F = + 30 mm

AV2-FCM = + 43 mm

AV2-VRS = + 25 mm

AV2-VRS-F = + 55 mm

AV2-VRS-FCM = + 53 mm

con chiocciola di sicurezza "G" aggiungere 30mm (Es. AV2-F opzione "G" = +30 +30)
with safety nut "G" add 30mm (i.e. AV2-F "G" option = +30 +30)

Dispositivo antirotazione

Nella famiglia AV2 è possibile installare un dispositivo antirotazione che vincola le rotazioni dell'asta traslante attorno al proprio asse. Con l'attacco anteriore A1 ed A2 sono disponibili due versioni: ARO con attacco anteriore nella posizione standard e AR1 con attacco anteriore ruotato di 90°. Nei casi di attacco A3, A4, A6 ed A7 è obbligatorio avere il dispositivo antirotazione. Perde di significato la distinzione in ARO e AR1: in questo caso si riporta sempre ARO.

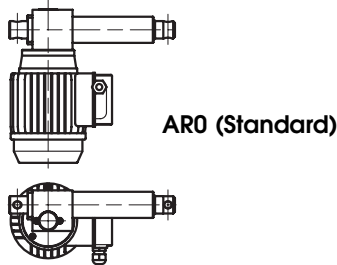

ARO (Standard)

Antirotation device

Model AV2 can host an antirotation device, allowing push rod not to spin when travelling. Front ends A1 and A2 allow for two antirotation settings, ARO and AR1. When using A3, A4, A6 and A7 front ends antirotation facility must always be mounted, but it makes no sense to specify it as ARO or AR1: so, ARO is in these cases then chosen.

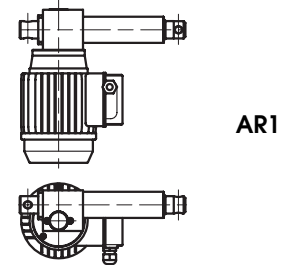

AR1

**Attacco posteriore
Rear end**

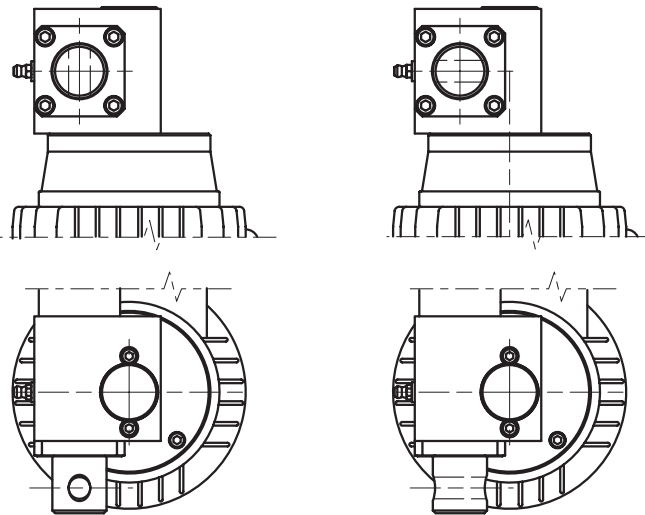

**P1
(Standard)**

**P2
Ruotato di 90° / 90° Rotated**

**Opzione "S" (solo per versione C.A.)
Option "S" (only for A.C. version)**

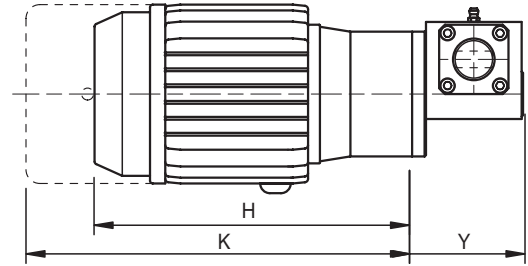

GR. MOTORE / MOTOR SIZE	VERSIONE / TYPE		H	K	Y
	56	Standard		206.5	
Autofrenante / Brake motors				238.5	
63	Standard		229.5		80
	Autofrenante / Brake motors			278.5	
71	Standard		264.5		87
	Autofrenante / Brake motors			311.5	

N.B.: L'intervento della frizione è ad un valore pari al 150/160% del carico nominale.

Note: clutch reacts at 150-160% of nominal load.

**Orientamento fine corsa
Limit switches side**

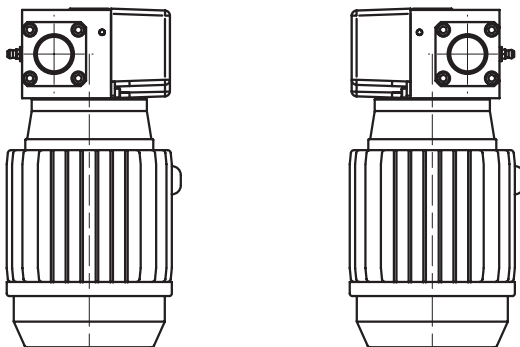

**FC1
(Standard)**

FC2

**Orientamento motore
Motor side**

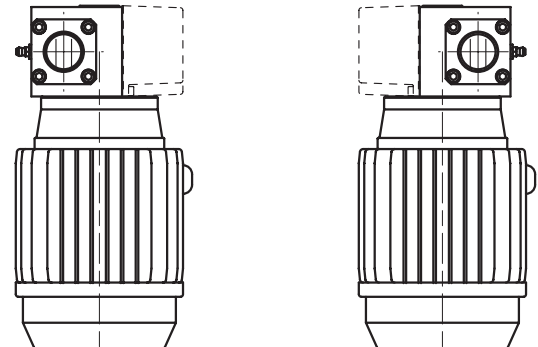

**M0 (Standard)
(solo FC1 / FC1 only)**

**M1
(solo FC2 / FC2 only)**

Orientamento morsettiera

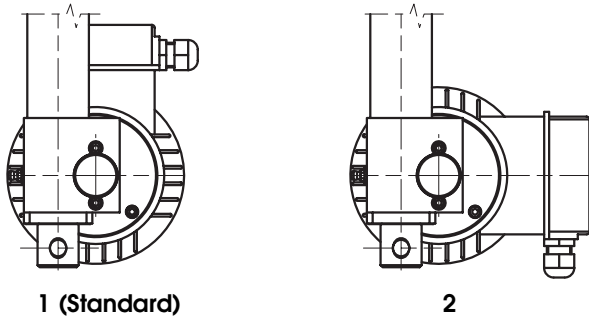

E-box side

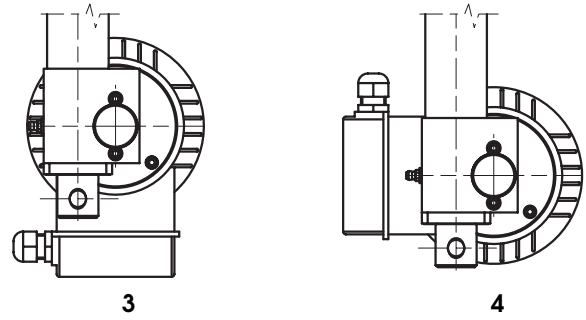

Dispositivi Controllo Corsa Elettrici / Elettronici

Electric/Electronic Stroke Control Devices

Fine corsa

Limit switches

Prestazioni / Performances	Tipo / Type	
	XGG	
Tensione / Voltage	230 Vac / 30 Vdc	
Carico resistivo / Resistive load	16 A	
Carico motore / Motor load	6 A	

Caratteristiche tecniche micro

Switches technicals features

Le caratteristiche dei microinterruttori di finecorsa montati sono le seguenti:

Limit Switches Features following:

- Alloggiamento: resina fenolica/melaminica termosaldada
- Meccanismo: azione a scatto con molla in bronzo/berillio. Un contatto in scambio NC/NO

- Housing: Phenolic-melamine thermosetting
- Mechanism: Snap-action coil spring mechanism with beryllium/bronze spring. Changeover, normally-closed / normally-open

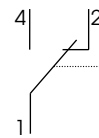
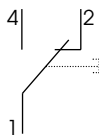

- Contatti: argento
- Terminali: dorati
- Vita meccanica: minimo 3x10⁵ azionamenti non impulsivi.

- Contacts: fine silver
- Terminals: gold flashed
- Mechanical life: 3x10⁵ cycle minimum (impact free actuation).

Potenziometro rotativo

Spinning potentiometer

Prestazioni / Performances	Tipo / Type (A) Standard	Tipo / Type (B) Speciale / Special
Angolo max. di lavoro / Max. angle	340° ± 3°	352° ± 2°
Resistenza Ohm / Resistance	1K / 5K / 10K (standard)	1K / 5K / 10K (standard)
Alimentazione consigliata / Voltage	MAX 10 V	MAX 50 V
Linearità indipendente / Independent linearity	± 2%	± 1%
Tolleranza / Tolerance	± 20%	± 3%
Coefficiente deriva termica / Temperature coefficient of resistance	600 ppm / °C	20 ppm / °C

A Versione / Version

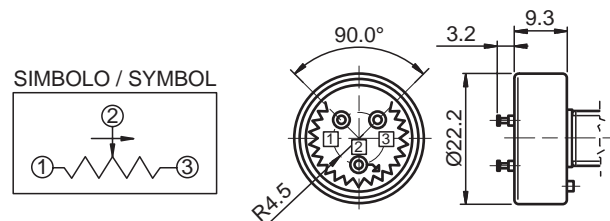

B Versione / Version

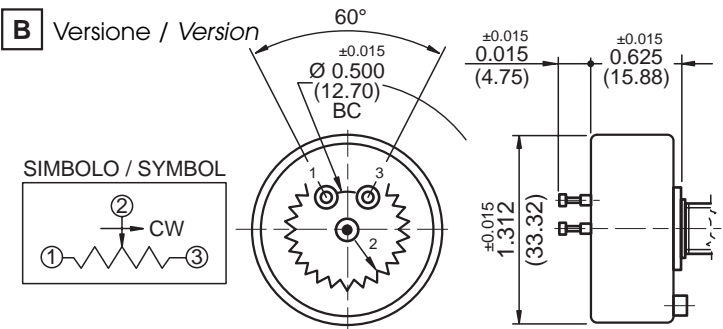

Gruppo controllo corsa

Control devices group

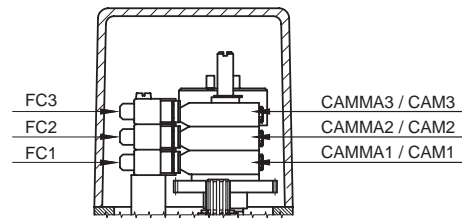
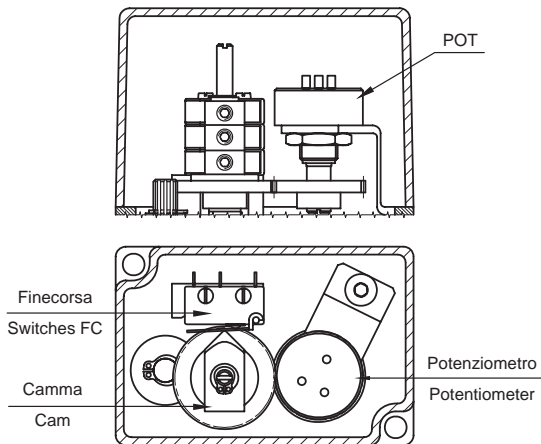

FC 1 - micro inferiore
FC 2 - micro centrale
FC 3 - micro superiore
CAMMA 1 - camma inferiore
CAMMA 2 - camma centrale
CAMMA 3 - camma superiore
POT - potenziometro

FC 1 - lower microswitch
FC 2 - middle microswitch
FC 3 - upper microswitch
CAM 1 - lower cam
CAM 2 - middle cam
CAM 3 - upper cam
POT - potentiometer

N.B.: la combinazione fine corsa + potenziometro dev'essere valutata con il nostro Ufficio Tecnico

Note: microswitches + potentiometer version pls. ask our Technical Dept.

Fine corsa magnetici FCM

Magnetic limit switches FCM

Prestazioni / Performances	Tipo / Type		
	DSM 1 H 425	DSL 1 C 225	DSL 4 N 225
Tensione in DC / DC voltage	3 / 110 V	3 / 30 V	6 / 30 V
Tensione in AC / AC voltage	3 / 110 V	3 / 30 V	/
Corrente a 25°C / 25°C Current	0,5 A	0,1 A	0,20 A
Potenza / Power	20 VA	6 VA	4 W
Tempo inserzione / ON time	0,5 ms	0,5 ms	0,8 ms
Tempo disinserzione / OFF time	0,02 ms	0,1 ms	0,3 ms
Cavo alimentazione / Supply cable	PVC 2 x 0,14 mm	PVC 2 x 0,14 mm	PVC 3 x 0,14 mm
Lunghezza cavo / Cablelength	2500 mm		
Protezione / Protection	IP67		

Circuito H (DSM)

Circuito con ampolla Reed normalmente chiusa protetta da varistore contro le sovratensioni generate all'apertura del circuito, e sistema di visualizzazione.

Circuit H (DSM)

Circuit with Reed switch normally closed protected by a varistor against overvoltages caused when switching off, with indicator.

Circuito N - PNP (DSL)

Circuito con effetto di Hall normalmente aperto con uscita PNP.

Protetto contro l'inversione di polarità e contro picchi di sovratensione.

LED GIALLO: presenza tensione (solo DSM), LED VERDE: carico inserito (LED giallo per DSL).

Circuit N - PNP (DSL)

Circuit with Hall-effect switch normally open with outlet PNP, protections against overvoltages spikes and reverse of polarity.

Yellow LED: Voltage in (only for DSM), Green LED: Load in (yellow LED for DSL).

Circuito C (DSL)

Circuito con ampolla Reed normalmente aperta, protetta da varistore contro le sovratensioni generate all'apertura del circuito, e sistema di visualizzazione.

Circuit C (DSL)

Circuit with Reed switch normally open protected by a varistor against overvoltages caused when switching off, with indicator.

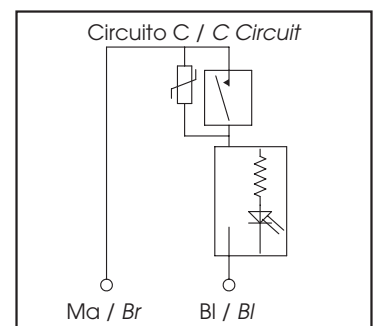
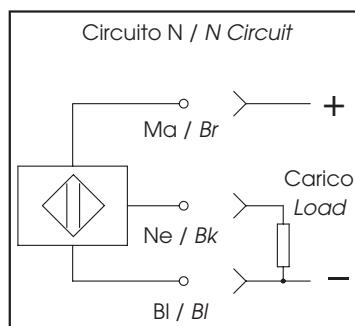
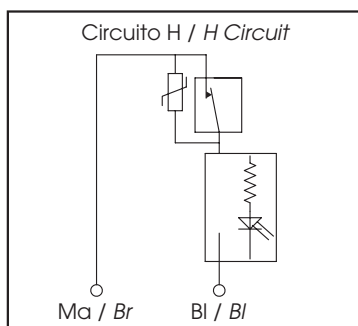

Caratteristiche tecniche Encoder

Encoder incrementale bidirezionale con (standard) e senza impulso di zero IP54.

Impulsi giro disponibili: 50 / 100 / 200 / 400 / 500 / 512 / 1000 / **1024 (standard)** / 2000 / 2048

Circuiti d'uscita disponibili: **Line Drive 5 Vdc (standard)** / Push Pull 24 Vdc / Open Collector NPN 10 -30 Vdc / Open Collector PNP 10 -30 Vdc.

- Applicato sui motori in C.A.

Encoder

Rosso / Red	+Vdc
Nero / Black	0 Vdc
Verde / Green	A
Giallo / Yellow	B
Blu / Blue	Z
Marrone / Brown	-A
Arancione / Orange	-B
Bianco / White	-Z

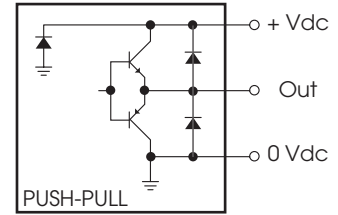
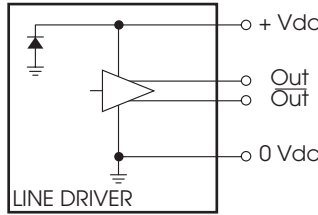

Encoder technical specs

Bidirectional incremental encoder, with (standard) or without zero-pulse, protection IP54.

Available ppr: 50 / 100 / 200 / 400 / 500 / 512 / 1000 / **1024 (standard)** / 2000 / 2048

Available output circuits: **Line Drive 5 Vdc (standard)** / Push Pull 24 Vdc / Open Collector NPN 10 -30 Vdc / Open Collector PNP 10 -30 Vdc.

- Incremental encoder installed directly on AC motors.

Encoder

Riferimento Sigla d'ordinazione

Fine Corsa Meccanici:

2FC2 = 2 Micro XGG
3FC2 = 3 Micro XGG

2FCD2 = 2 Micro XGG cablati con diodi
3FCD2 = 3 Micro XGG di cui 2 cablati con diodi

Solo per motori DC
e per carichi fino a 6A di assorbimento

Fine Corsa Magnetici:

2FCM0= 2 Sensori DSM.1H — Versione Standard in assenza di indicazioni
2FCM1= 2 Sensori DSL.1C
2FCM2= 2 Sensori DSL.4N
3FCM0= 3 Sensori DSM.1H — Versione Standard in assenza di indicazioni
3FCM1= 3 Sensori DSL.1C
3FCM2= 3 Sensori DSL.4N

Potenziometri:

POT01A = 1 k Ohm
POT05A = 5 k Ohm
POT10A = 10 k Ohm

Versioni Standard

POT01B = 1 k Ohm
POT05B = 5 k Ohm
POT10B = 10 k Ohm

Versioni Speciali

Encoder:

E05 = Push Pull 1024 ppr
E06 = Line Drive 1024 ppr — Versione Standard
E07 = Open Collector NPN
E08 = Open Collector PNP

Solo su Motore C.A.

E09 = Push Pull 1024 ppr
E10 = Line Drive 1024 ppr
E11 = Open Collector NPN
E12 = Open Collector PNP

Solo su Cassa Attuatore

E13 = Encoder non contemplato
(indicare le caratteristiche nel disegno d'assieme)

Ordering Key references

Mechanical limit switches:

2FC2 = 2 Microswitches XGG
3FC2 = 3 Microswitches XGG

2FCD2 = 2 XGG Microswitches diode-wired
3FCD2 = 3 XGG Microswitches, 2 of them diode-wired

For DC motors only
and for loads up to 6A

Magnetic limit switches:

2FCM0= 2 Sensori DSM.1H — Standard Version without prior information
2FCM1= 2 Sensori DSL.1C
2FCM2= 2 Sensori DSL.4N
3FCM0= 3 Sensori DSM.1H — Standard Version without prior information
3FCM1= 3 Sensori DSL.1C
3FCM2= 3 Sensori DSL.4N

Potentiometer:

POT01A = 1 k Ohm
POT05A = 5 k Ohm
POT10A = 10 k Ohm

Standard Versions

POT01B = 1 k Ohm
POT05B = 5 k Ohm
POT10B = 10 k Ohm

Specials Versions

Encoder:

E05 = Push Pull 1024 ppr
E06 = Line Drive 1024 ppr — Standard Version
E07 = Open Collector NPN
E08 = Open Collector PNP

With AC motor only

E09 = Push Pull 1024 ppr
E10 = Line Drive 1024 ppr
E11 = Open Collector NPN
E12 = Open Collector PNP

On actuator case only

E13 = Special encoder
(advise features in drawing)

Guida alla scelta della motorizzazione - *Motor choice guideline*

TIPO MOTORE / MOTOR TYPE

- Versione / Version:** **CA** = corrente alternata / **AC** = alternate current
PD = PAM a disegno / *Special motorflange (provide drawing)*
- Tensione / Voltage:** CA / AC = 230/400/50 – 190/330/50 – 208/360/50 – 400/690/50
 277/480/60 – 220/380/60 – 254/440/60 – 480/830/60 - **MT** = Multitensione / *Multivoltage*
 230/50 (monofase / *1-phase*)
- Tipo / Type:** **T** = trifase / *3-phase*
M = monofase / *1-phase*
AT = trifase autofrenante / *3-phase with brake*
AM = monofase autofrenante / *1-phase with brake*
ME = monofase con condensatore elettronico / *1-phase with starting capacitor*
AE = monofase con condensatore elettronico autofr. / *1-phase with brake and starting capacitor*
- Grandezza / Size:** CA / AC: IEC 56 / 63 / 71
- N° Poli / Poles:** **CA / AC:** 2 / 4

Potenza CA / AC Power: kW

IEC IEC	kW trifase / 3-phase			kW monofase / 1-phase		
	2POLI 2POLES	4POLI 4POLES	6POLI 6POLES	2POLI 2POLES	4POLI 4POLES	6POLI 6POLES
56	0,09 / 0,13	0,06 / 0,09 / 0,11	-	0,08 / 0,12	0,09 / 0,11	-
63	0,18 / 0,25 / 0,37	0,13 / 0,18 / 0,22	-	0,18 / 0,25	0,12 / 0,18 / 0,22	-
71	0,37	0,25 / 0,37	-	0,37	0,25 / 0,37	-

VARIANTI MOTORE / MOTOR OPTIONS

Flangia tipo / Motorflange type: PAM56B14 / PAM63B14 / PAM71B14

Tipo servizio / Service rate: **S1 / S2 / S3**

Classe isolamento / Insulation class: **F** = standard (**non indicare**) / *standard (leave blank)*
Specificare solo se diversa / Advise only if different than "F"

Grado Protezione / Degree protection: **IP55** standard (non indicare / *leave blank*)
IP65
TP = tropicalizzato / *tropicalization*

Freno / Brake: **FECC** = freno elettromagnetico in CC / *DC brake*
FECA = freno elettromagnetico in CA / *AC brake*
SENZA = omettere / **NO BRAKE** = *leave blank*

Opzioni / Options: **LS** = leva sblocco / *hand release lever* (non indicare / *leave blank*)
N.B.: non disponibile per motori IEC 56 / **Note:** *not available for motor IEC 56*
AB = albero bisorgente / *2' shaft*
IN = avvolgimento per inverter / *winding for inverters*
ALTRO / OTHER = indicare per esteso / *advise*
SENZA / NONE = omettere / *leave blank*

SIGLA DI ORDINAZIONE - ORDERING KEY

AV2 / 0250 / M01 / CA-400/50 - T-56-4-0,09 / B5+S1+AB / FC1 / M0 / 1 / EO / 2FC0 / POT01A / IP65 / AR0 / P1 / A1 / A+B / N.DIS

MODELLO / MODEL:

AV2 AV2-VRS
AV2-F AV2-VRS-F
AV2-FCM AV2-VRS-FCM

CORSA / STROKE: mm
es. 250 mm = 0250

VELOCITÀ / SPEED: mm/s Pag. 95

Indicare: vedi tabelle

Advise: choose among

M00 = Velocità non contemplate / Speed to be provided

Versione PAM / PAM Version:

indicare Rapporto Riduzione + Passo Stelo

Advise reduction ratio and screw pitch

MOTORE / MOTOR: Pag.104

Indicare solo con motore: / Advise only if with motor:

In C.A.: versione / tensione / tipo / grandezza / n° giri / potenza
version / voltage / type / size / Rpm / power

In versione predisposizione motore "PAM" indicare: 0

In version with motorflange only PAM: 0

In versione PAM a Disegno indicare: PD

In version with special motorflange: PD

VARIANTI MOTORE / MOTOR OPTIONALS: Pag.104

Flangia motore: solo in versione PAM esempio PAM 56B14 indicare: 56B14

Motorflange: Motorflange version only PAM advise size as 56B14: 56B14

Senza motore: Omettere tutti i parametri sottoindicati

No motor: leave all following parameters blank

Tipo Servizio: Indicare se diverso da S3 (standard)

Service type: Advise if different than S3 (standard)

Classe isolamento: Indicare se diverso da F (standard)

Insulation class: Advise if different than F (standard)

Grado Protezione: Indicare se diverso da IP55 (standard)

Protection: Advise if different than IP55 (standard)

Tipo freno: solo se autofrenante: ES, FECA

Brake type: for brakemotors only: ES, FECA

Opzioni: Indicare se richiesto ES, AB= Albero Bisporgente

Options: Advise if needed ES, AB= 2' shaft

ORIENTAMENTO FINE CORSA / LIMIT SWITCHES SIDE: Pag. 100

Senza / None: Omettere / Leave blank

FC1 / FC2

ORIENTAMENTO MOTORE / MOTOR SIDE: Pag. 100

Senza / None: Omettere / Leave blank

M0 / M1

ORIENTAMENTO MORSETTIERA / E-BOX SIDE: Pag. 101

1 (Standard), 2, 3, 4

Senza Motore / No Motor: Omettere / Leave blank

TIPO ENCODER / ENCODER TYPE: Pag. 103

Senza / None: Omettere / Leave blank

FINE CORSA / LIMIT SWITCHES: Pag. 103

Senza / None: Omettere / Leave blank

POTENZIOMETRO / POTENTIOMETER: Pag. 103

Senza / None: Omettere / Leave blank

GRADO PROTEZIONE / PROTECTION CLASS:

IP50 (Standard): Omettere / Leave blank

IP65

DISPOSITIVO ANTIROTAZIONE / ANTIROTATION DEVICE: Pag. 100

Senza / None: Omettere / Leave blank

AR0: Standard

AR1: 90°

ATTACCO POSTERIORE / REAR END: Pag. 100

P0 = Senza / None

P2 = Occhio / Eyelet (90°)

P1 = Occhio / Eyelet (standard)

P3 = Attacco a Disegno / Special (provide drawing)

ATTACCO ANTERIORE / FRONT END: Pag. 99

A0 = Senza / None

A4 = Testa a Snodo / Rod end

A1 = Occhio / Eyelet (Standard)

A6 = Filetto Femmina M12 / M12 female

A2 = Forcella Fissa / Yoke

A7 = Filetto Maschio M12 / M12 male

A3 = Forcella + Clip / Yoke + Clip

A9 = Attacco a Disegno / Special (provide drawing)

OPZIONI / OPTIONS:

Senza / None: Omettere / Leave blank

A = Versione Inox (asta, attacco anteriore) /

E = Guarnizioni in Viton / Viton joints

F = Verniciatura / Painting

S = Limitatore di coppia su asse motore (pag. 100) /
Torque limiter on motor flange (pag. 100)

C = Vite Scoperta / Naked Screw

G = Chiocciola di Sicurezza (vedere note pag. 99) /
Safety nut (see note pag. 99)

T = Sporgenza albero opposta motore (solo Vac) /
Additional shaft

L = Antirotazione / Anti-rotation device

(opposite to motorside - Vac only)

VARIANTI / VERSIONS:

N° Disegno / Drawing number: Per Condizioni non Contemplate / Drawing to be provided

Senza / None: Omettere / Leave blank

